

VEP K4-PVC

Electrically actuated butterfly valves



INSTRUCTIONS MANUAL

BAMO MESURES

22, Rue de la Voie des Bans - Z.I. de la Gare - 95100 ARGENTEUIL

Tél : (+33) 01 30 25 83 20 - Web : www.bamo.fr

Fax : (+33) 01 34 10 16 05 - E-mail : info@bamo.fr

Electrically actuated
butterfly valves
VEP SK4-PVC

02-01-2012

914 M1 03 C

PLAS

914-03/1

DESCRIPTION

Electric actuators are designed for controlling quarter turn plastic valves. For any other purpose, please report to us before start up; we may not be responsible of troubles due to other applications.

1. Fitting on the pipe line

1.1. Precautions

Before fitting the valve, it is necessary to verify the chemical compatibility between all the elements (*fluid vs. body, seals, seating joints*).

1.2. Assembly

Respect common precautions for the assembly of all elements together.
All parts should correspond in dimensions, pressure & temperature limits.

2. Electric motor connections

2.1. Precautions

- Fitting, connections, initial start-up and maintenance operations must be done by trained technicians.
All European and local rules for electric devices and systems must be respected.
- Follow the recommendations step by step as per following texts, otherwise a correct operation is not warranted.
- Check if the power supply input corresponds to the main power available on site (tag on the electric actuator)
- Do not fit the actuator head down.
- Do not fit the actuator at less than 30 cm from electromagnetic disturbance source.
- Do not wire several actuators on one reversing switch without lines separation
- **Shut off the main power supply before any operation such as:**
 - Opening the cover
 - Unlocking the clutch
 - Manual operating for emergency or maintenance
- The engine was tested on bench before shipment.
Limit switches are adjusted for a rotation of 90° (you may not have to modify this).
- Verify before mounting, the free rotation in place of manual handle (emergency manual override).
- The complete electric actuator is protection class IP65 and no need a specific maintenance.
- **An electric protection must be install (circuit-breaker, etc.) according to the engine power.**

2.2. Wiring and connecting automatism and power circuits

- Connection to earth (ground) is an obligation over 42 V voltage (today standards).

ND65 to ND100

- 3 Wires+Ground
DIN436560 connector

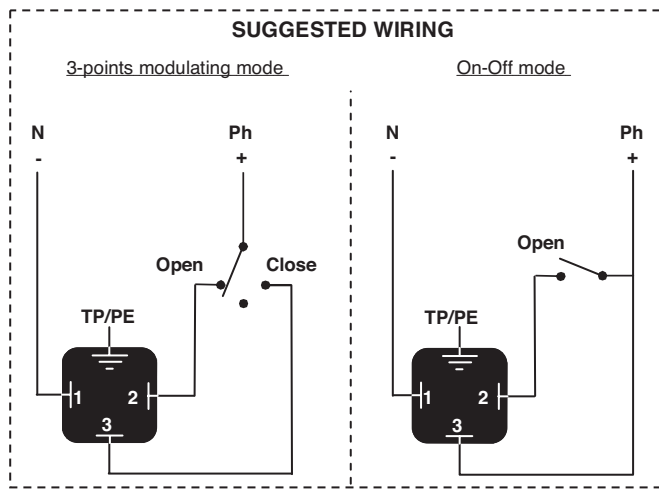

ND150 to ND200

- Connect to the earth through the exterior bolt M5 located under the cable gland.
(It is also possible to connect the actuator to earth inside the actuator through the bolt M3 next to the terminal strip)
- Unscrew the left cable gland and insert the cable.
- Connect the wires to the terminal strip in accordance with the required control mode.

3-points modulating mode

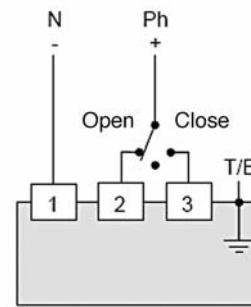

On-Off mode (pre-set to close)

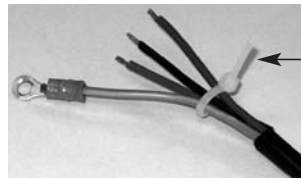
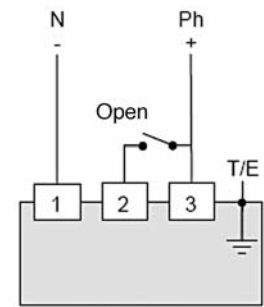

Put a lacing cord around the wires and re-tighten the cable gland.

Alternative current:

- Connect the earth (yellow/green wire) to TP/PE
- Connect Neutral in 1
- Connect opening signal wire to 2
- Connect closing signal wire to 3

Direct current:

- Connect 1 and 2 to the relay (or double reversing switch) necessary for a good direct current working.
- Make a shunt between 2 and 3

The earth connection is not necessary in low voltage.

Switch the connection if open close functions are not good.

2.3. Limit switches (See §5. Wiring diagram)

2 limit switches box are include in standard and they are set for a 90° rotation.

DN65 to ND100:

- Remove the manual emergency override or visual position indicator
- Remove the cover by unscrew the 4 screw
- Loosen the ISO M20 gland to reeve the wire
(ISO M20 gland is useful for 5.5 to 12 mm cable)

Now with the cover remove and the ISO M20 gland loosen you can plug the wires like this:

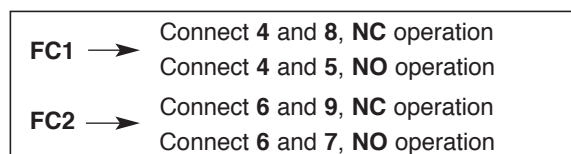

- For re-assembling the actuator make this operation in the reverse order

ND150 to ND200

Our actuators are equipped with two simple limit switch contacts normally set in their open position (NO). As per factory setting, the white cam is used to detect the open position (FC1) and the black cam is used to detect the closed position (FC2). This feedback system accepts voltages between 24 V and 240 V AC/DC.

- Unscrew the right cable gland and insert the cable.
- Remove 25mm of the cable sheath and strip each wire by 8mm.
- Connect the wires to the terminal strip in accordance with the diagram beside.
- Tighten the cable gland.

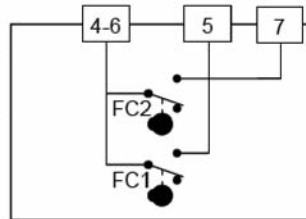

3. Emergency manual override

The priority functioning mode of this actuator is electric. Be sure that the power supply is switched off before using the manual override.

ND65 to ND100

- Turn the knob to position **MAN** (counter-clockwise) and hold it in position.
- Turn the outgoing drive shaft of the actuator with the help of an adjusting spanner.
- In order to re-engage the reduction, release the knob (spring return).

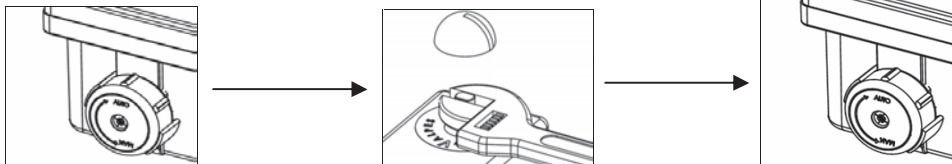

ND150 to ND200

- Hand wheel emergency manual override
- No declutching is required
 - The hand wheel has simply to be turned

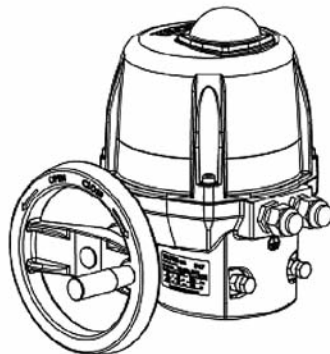

4. Technical data

ND65 to ND100

| | |
|---|--|
| IP Protection: | IP65 (dusttight, water spraying "flow < 12.5l/min") |
| Corrosion resistance (<i>outdoor and indoor use</i>): | Plastic: PA6.6, ABS, raw material: 304L Stainless or steel + An treatment |
| Temperature: | -10°C to +55°C |
| Hygrometry : | < 81% to 31°C (88°F) with lineary decrease down to 50% at 40°C (according EN61010-1) |
| Pollution degree: | Class 2 |
| Altitude: | 0 to 2000m |
| Operating time: | around 10s |
| Rotation angle: | 90° |
| Manual override: | Out axle |
| Voltage: | 24V AC/DC 90V to 240V AC (90V to 350V DC) |
| Frequency: | 50/60Hz |
| Power: | 15W or 45W |
| Overvoltage category: | Category II |
| Torque limiter: | Electric |
| Duty rating: | 30% |
| Limit switches maximal voltage: | 4V to 250V AC/DC |
| Limit switches maximal current: | 10mA to 5A max |
| Electrical wiring: | 1 ISO M20 gland, 1 DIN43650 3P+T connector |



Follow the voltage tag on the actuator

ND150 to ND200

| | |
|---|---|
| IP Protection: | IP67 |
| Corrosion resistance (<i>outdoor and indoor use</i>): | Housing: Aluminium + EPOXY paint, Cover PA 6.6 V0, Drive: Steel + Zn Treatment, Axles and screws: Stainless steel |
| Temperature: | -20°C to +55°C |
| Hygrometry : | < 81% to 31°C (88°F) with lineary decrease down to 50% at 40°C (according EN61010-1) |
| Pollution degree: | Class 2 |
| Altitude: | 0 to 2000m |
| Operating time: | 30s to 60s |
| Rotation angle: | 90° |
| Manual override: | Hand wheel |
| Voltage: | 24V AC/DC 90V to 240V AC (90V to 350V DC) |
| Frequency: | 50/60Hz |
| Power: | 45W |
| Overvoltage category: | Category II |
| Insulation motor class: | Class B |
| Torque limiter: | Electric |
| Duty rating: | 50% |
| Limit switches maximal voltage: | 250V AC/DC |
| Limit switches maximal current: | 5A max |
| Electrical wiring: | 2 ISO M20 gland |
| Regulated heating resistor power: | 10W |
| Inrush current: | 35A |



Follow the voltage tag on the actuator

4.1. Exploded view ND65 to ND100

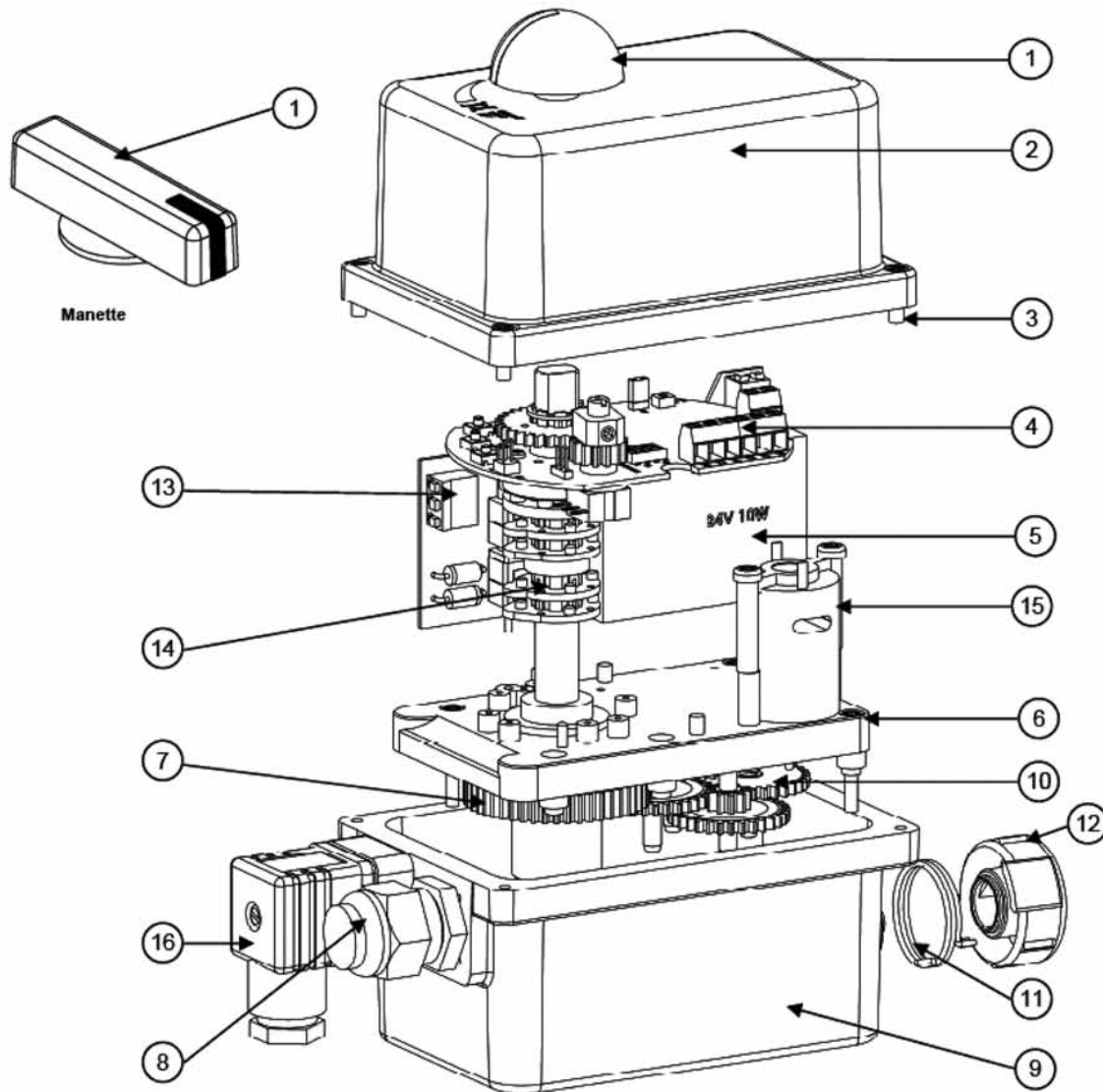

| Rep. | Désignation | Designation | Bezeichnung |
|------|----------------------------------|---------------------------------|---|
| 1 | Indicateur visuel de position | Visual position indicator | Stellungsanzeige |
| 2 | Capot ABS | ABS cover | ABS Haube |
| 3 | Vis inox | Stainless steel screws | Edelstahl Schrauben |
| 4 | Bornier signal entrée / sortie | Input / output terminal trip | Anschlussklemmen des Signalgebers / Rückmeldung |
| 5 | Carte d'alimentation | Power supply card | Stromversorgung Karte |
| 6 | Plaque réducteur | Gear box plate | Getriebeplatte |
| 7 | Entraîneur | Shaft + sleeve | Antriebswelle |
| 8 | Presse-étoupe ISO M20 | ISO M20 gland | PG Schrauben ISO M20 |
| 9 | Carter Nylon | Nylon housing | Gehäuse |
| 10 | Engrenages | Gears | Getriebe |
| 11 | Ressort | Spring | Feder |
| 12 | Bouton de débrayage | Clutch knob | Schaltknopf |
| 13 | Bornier fin de course auxiliaire | Aux. Limit switch terminal trip | Zusätzlicher Endschalter |
| 14 | Cames | Cams | Nocken |
| 15 | Moteur | Motor | Motor |
| 16 | Connecteurs 3P+T (DIN436560) | Connectors 3P+T (DIN436560) | Gerätesteckdosen 3P+T (DIN436560) |

4.2. Exploded view ND150 to ND200

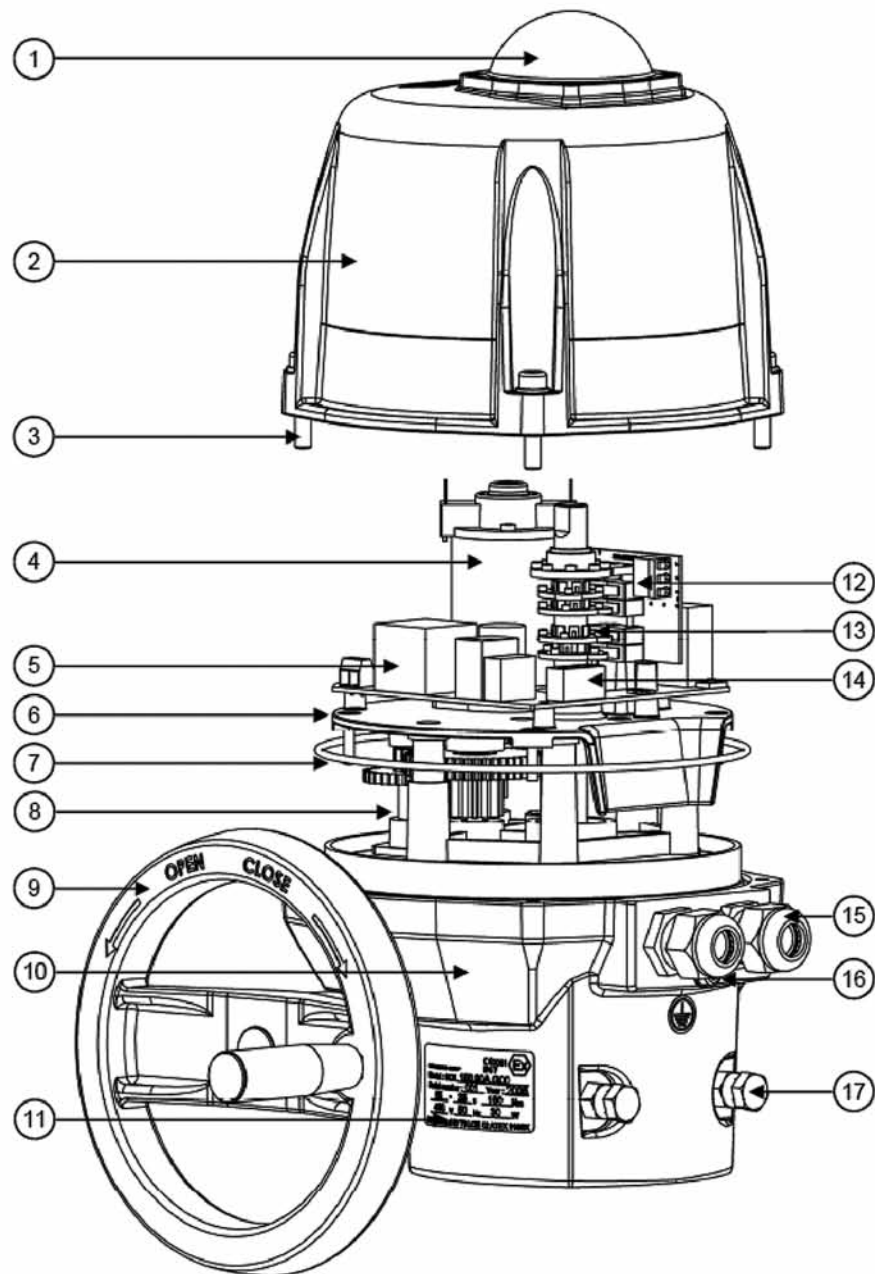

| Rep. | Désignation | Designation | Bezeichnung |
|------|----------------------------------|---------------------------------|--|
| 1 | Indicateur visuel de position | Visual position indicator | Stellungsanzeige |
| 2 | Capot | Cover | Haube |
| 3 | Vis inox | Stainless steel screws | Edelstahl Schrauben |
| 4 | Moteur | Motor | Motor |
| 5 | Carte alimentation et commande | Pilot and power supply card | Steuerung und Stromversorgung Karte |
| 6 | Plaque réducteur | Gear box plate | Getriebeplatte |
| 7 | Joint torique | O ring | O Ringdichtung |
| 8 | Réducteur | Gear box | Getriebe |
| 9 | Volant | Hand wheel | Handrad |
| 10 | Carter | Housing | Gehäuse |
| 11 | Étiquette d'identification | Identification label | Identifizierungsetikett |
| 12 | Bornier fin de course auxiliaire | Auxiliary limit switch terminal | Zusätzlicher Endschalter Verbindung |
| 13 | Cames | Cams | Nocken |
| 14 | Bornier alimentation et commande | Pilot and power supply terminal | Steuerung und Stromversorgung Verbindung |
| 15 | Presse-étoupe ISO M20 | ISO M20 gland | PG Schrauben ISO M20 |
| 16 | Vis de terre | Earth screw | Erde Schraube |
| 17 | Butées mécaniques | Mechanical end stops | Mechanische Endhalterung |

5. Electric wiring

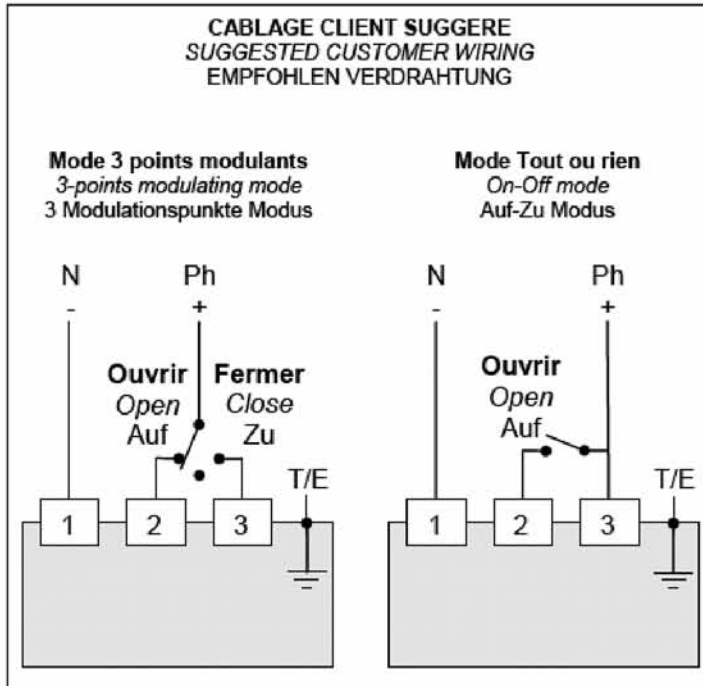

| REP | DESIGNATION BESCHREIBUNG |
|-----|--|
| FC0 | Fin de course ouverture <i>Open limit switch</i> Endschalter AUF |
| FCF | Fin de course fermeture <i>Close limit switch</i> Endschalter ZU |
| FC1 | Fin de course auxiliaire 1 <i>Auxiliary limit switch 1</i> Zusätzlicher Endschalter 1 |
| FC2 | Fin de course auxiliaire 2 <i>Auxiliary limit switch 2</i> Zusätzlicher Endschalter 2 |



TENSION INDIQUEE SUR L'ACTIONNEUR : 24V AC/DC ou 100-240V AC (120-350V DC)
INDICATED VOLTAGE ON ACTUATOR : 24V AC/DC or 100-240V AC (120-350V DC)
SPANNUNG, DIE AUF ANTRIEBE GEZEIGT IST : 24V AC/DC ODER 100-240V AC (120-350V DC)

ALIMENTATION ET COMMANDE
POWER SUPPLY AND COMMAND
SPANNUNGSVERSORGUNG UND STEUERUNG

RECOPIE
FEEDBACK
RÜCKMELDUNG

