

AS2 & AS3

**Free chlorine at constant pH  
or  
Chlorine dioxide sensor**



**INSTRUCTIONS MANUAL**

**BAMO MESURES**

22, Rue de la Voie des Bans - 95 100 ARGENTEUIL - FRANCE

Phone +33 (0)1 30 25 83 20 - E-mail: [info@bamo.fr](mailto:info@bamo.fr)

Fax: +33 (0)1 34 10 16 05 - <http://www.bamo.eu>

AMPEROMETRIC SENSOR  
**AS2 & AS3**

AC prov 1012

**MSA**

**193-13**

PARAMETER	Synonymous	Components	Chemical formula	EVALUATION
<b>Potential chlorine</b>		Hypochlorite ions Chloro-cyanurates	$\text{OCl}^-$ $\text{ClCy}$	Difference between free chlorine and active chlorine concentrations
<b>Active chlorine</b>	Free active chlorine	Elementary chlorine Hypochlorous acid	$\text{Cl}_2$ $\text{HOCl}$	According to pH and chlorine percentage (see dissociation curve)
<b>Free chlorine</b>	Total free chlorine	Elementary chlorine Hypochlorous acid Hypochlorites	$\text{Cl}_2$ $\text{HOCl}$ $\text{OCl}^-$	BAMO kits or meters using DPD1
<b>Combined chlorine</b>	Chloramines (organic compounds under destruction)	Monochloramine Dichloramine Trichloramine	$\text{NH}_2\text{Cl}$ $\text{NHCl}_2$ $\text{NCl}_3$	Difference between free chlorine and total chlorine concentrations
<b>Total chlorine</b>		Elementary Chlorine Hypochlorous Acid Hypochlorites Dichloramine	$\text{Cl}_2$ $\text{HOCl}$ $\text{OCl}^-$ $\text{NHCl}_2$	BAMO kits or meters using DPD4 (or 1+3)
<b>Chlorides</b>	Inert chloride Reduced chloride	Chlorides	$\text{NaCl}$ $\text{CaCl}_2$	
<b>Stabilizer</b>		Isocyanuric acid		

### Chlorine dissociation diagram

Example: active chlorine at pH 7.2 corresponds to 68% of free chlorine available in the water

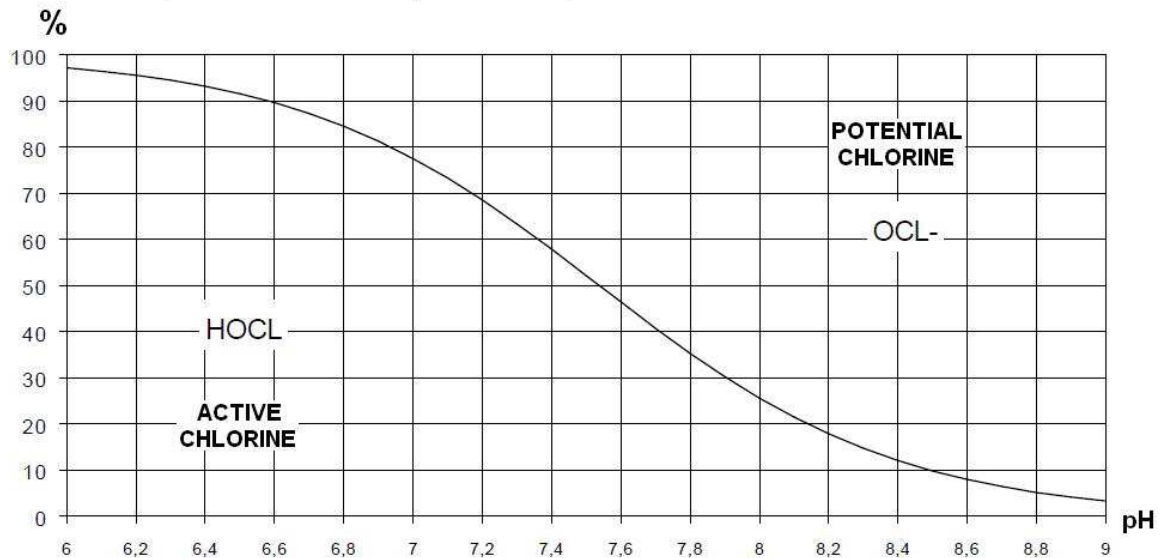

## 1. SENSORS AS2 and AS3, PRINCIPLE

The Amperometric sensors AS2 and AS3 are a mixed of open and closed cell type. AS2 are for working at up to 50°C and AS3 up to 70°C. The sample is not wasted, sampling loop in line with specific assembly. The reference electrode is in contact with electrolyte inside the sensor end; the measuring electrode and counter-electrode are in direct contact with the flowing sample. Chlorine or chlorine dioxide is reduced on the cathode. The induced current is proportional to chlorine or chlorine dioxide concentration. For a correct measurement pH must be constant.

- The sensor is free from zero calibration

- **Transmitter and sensor must be energized at anytime.** Do not shut off the 2 wire powered loop, keep the monitor turned on all the time

## 2. FEATURES

### 2.1 Technical features

Range:	0.03 to 5 ppm (free chlorine or chlorine dioxide, different sensors) – at constant pH
Operating pH range:	From 5 to 9 pH
Power supply:	2 wire technique, 12 ... 30 V dc, $[R_{max} = (U-7,5) / 20 \text{ kOhm}]$ Cross section 0.25 mm <sup>2</sup>
Pressure limit:	8 bar as a maximum
Temperature limits	AS2: 5 to 50°C; AS3: 5 to 70°C
Flow rate limits:	From 30 to 40 L/h
Materials	AS2: PVC-U; AS3: PEEK
Dimensions:	Diam. 25 mm, length 225 mm

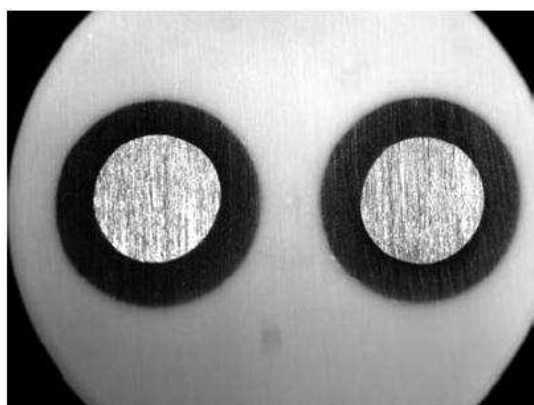
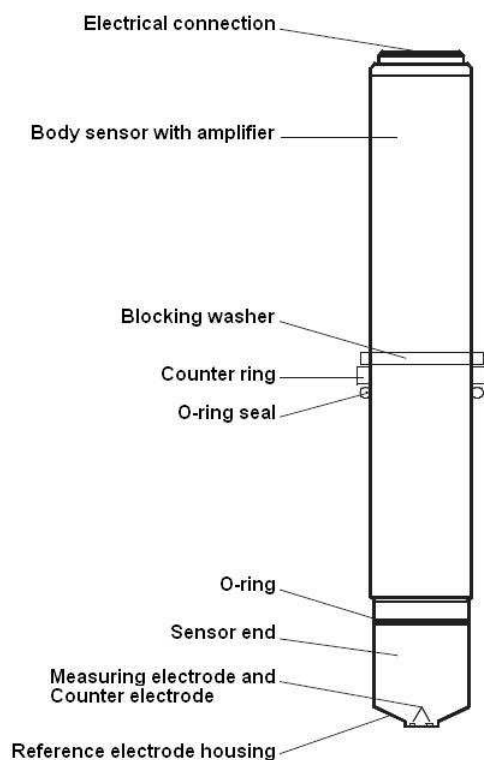

Bottom view of measuring electrode and counter electrode

### 2.2 Code numbers and references

#### Free Chlorine

Code	Reference	Range	Temp. max.	Resolution	Output	Power
193 223	AS2MA1.CL	0.03 to 1 ppm	50°C	0.01 ppm	4-20 mA	12...30 V dc
193 225	AS2MA5.CL	0.03 to 5 ppm				
193 228	AS3MA1.CL	0.03 to 1 ppm	70°C			
193 230	AS3MA5.CL	0.03 to 5 ppm				

#### Chlorine dioxide

Code	Reference	Range	Temp. max.	Resolution	Output	Power
193 224	AS2MA1.CD	0.03 to 1 ppm	50°C	0.01 ppm	4-20 mA	12...30 V dc
193 226	AS2MA5.CD	0.03 to 5 ppm				
193 229	AS3MA1.CD	0.03 to 1 ppm	70°C			
193 232	AS3MA5.CD	0.03 to 1 ppm				

#### Replacement parts

Code	Reference	Designation
193 962	EAS1/G	Electrolyte for AS2 and AS3 sensors (50 mL flask)

### 3. TYPICAL MEASURING SYSTEM

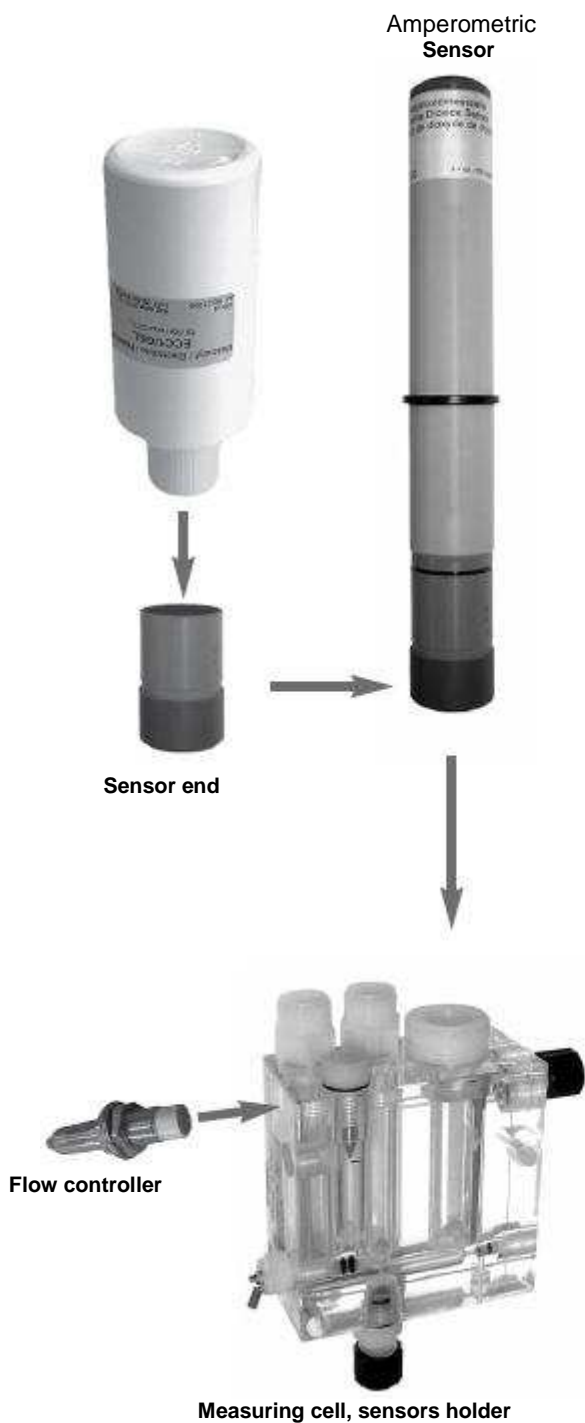

**Monitor**  
Example: BAMOPHOX 194

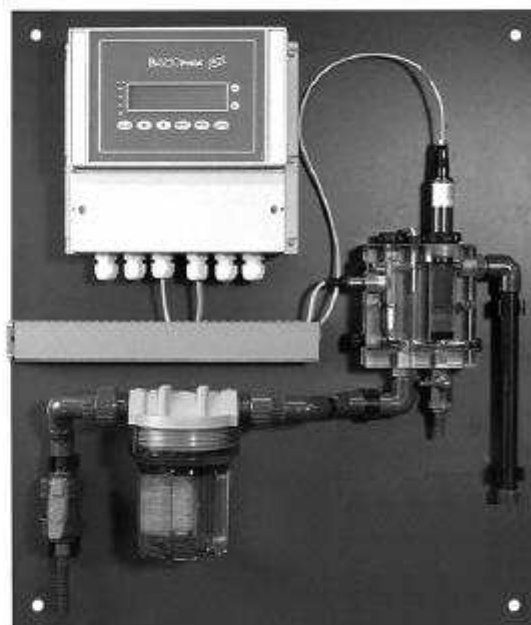

Example of a complete assembly

## 4. PREPARING THE SENSOR



The electrodes must not be touched with fingers

Sensors AS2 and AS3 are delivered with a filled sensor end for storage conditions  
Electrolyte should be change before first set up

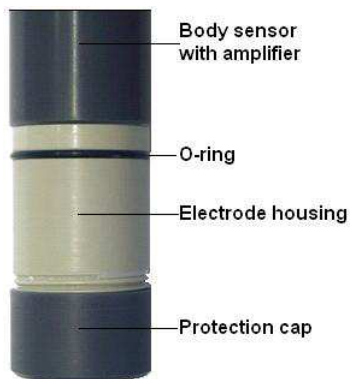

### a/ CAUTION, before refill

- Unscrew the protection cap
- Screw out the sensor end
- Clean with tap water sensor end and electrodes

### b/ Filling the sensor end

- Unscrew the sensor end from the sensor body.
- Unscrew the protection cap.
- Fill up the protection cap with electrolyte and screw it on the sensor end
- Screw the protection cap on the sensor end
- Screw on the body sensor, partially to allow the fill up of the sensor end with electrolyte; fill up to the edge
- Be careful there are no bubbles inside the sensor end



### c/ Screwing back the sensor end on the sensor body

- Hold the sensor body upright
- Screw gently the sensor body clockwise (by hand) onto the sensor end.
- Exceeding electrolyte will escape freely

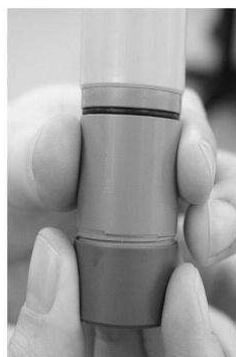

### d/ Checking up the sensor

- Check whether the sensor end is completely screwed in up to the stop.
- The first screw-in resistance comes from the O-ring seal.  
However the screwing procedure of the cap must be continued until it hits the adapter!
- Wash up the excess electrolyte with water.

Take off the protection cap before fitting the sensor in the measuring cell

## 5. FITTING THE SENSOR IN MEASURING CELL

Amperometric sensors are usually fitted in a specific measuring cell in PMMA, designed to hold various sensors together (*chlorine, temperature, pH, flow controller, etc.*) allowing a correct flow of the sampled fluid. Measuring cells exist for different applications and mounted in option on specific complete assemblies with a monitor BAMOPHOX 194.

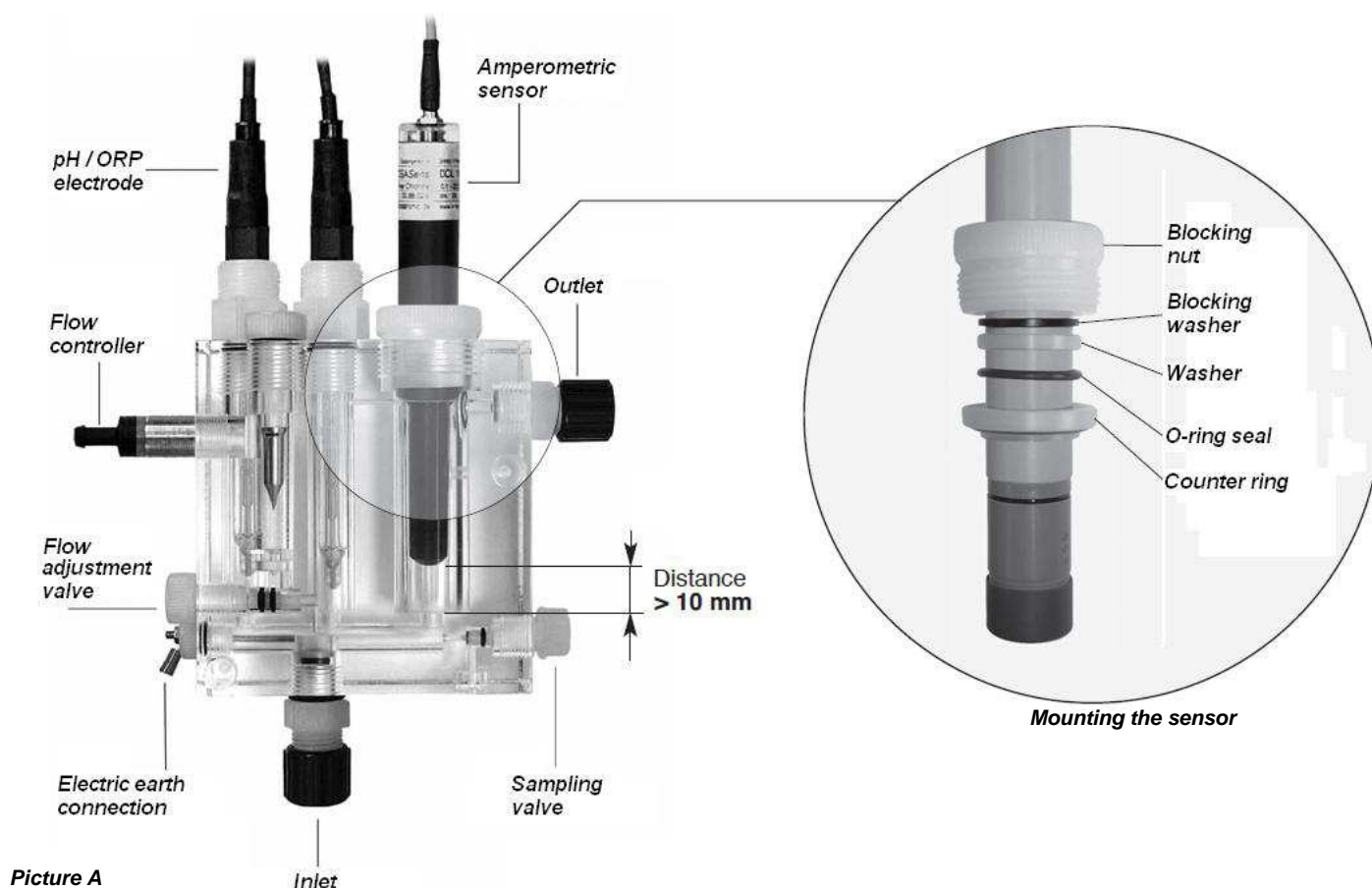

Picture A

### 5.1 Fitting the amperometric sensor

Take off the protection cap (keep it for maintenance purposes).

To fit the sensor probe in the measuring cell, respect the position of each part and then insert the sensor into the measuring cell.

Screw in the blocking nut, not tightly to allow the sensor body sliding inside the measuring cell



Position the sensor: **leaving more than 10 mm distance free from the bottom** (see the picture A).

Make sure that the sensor is tightly fastened in place; otherwise it may be pressed out under pressure.

The label should be kept visible.

### 5.2 Electric connections

A complete system with a BAMOPHOX 194 is highly recommended. This allows a direct measurement through the 2 wire loop, powering the sensor and protecting it against reversed polarity.

- Connect the probe with the BAMOPHOX 194 (see the specific instructions manual).
- On similar monitors, connect the sensor respecting the polarity.

## 6. CALIBRATION

It is necessary to proceed to a calibration, even if sensors are already factory calibrated.

- Open slowly the valve of sample water supply. One hour of free flowing sampled water is necessary for a good polarisation, before to proceed to the slope adjustment. The adjustment should be repeated after approximately 24 hours, after a complete check up.

- The flow rate is ideally 40 L/h and constant (or constant between 30 and 100 L/h)
- Operating pressure must not exceed the measuring cell pressure limit: 6 bar
- Operating water temperature, AS2: 5 to 50°C; AS3: 5 to 70°C

Test the value of free chlorine with the DPD1 method (*handheld colorimeters from BAMO*); note the value in mg/L.

Or

Test the value of chlorine dioxide with the DPD1 method, apply the factor 1.9 and note the value in mg/L (*Value = DPD1 reading x 1.9*)

This value has to be captured as the "SLOPE" value in the BAMOPHOX 194 (see the specific instructions manual of your monitor).

Once all parameters are respected, the complete system is ready for operating.

In case of dysfunction, see the § 10 *DYSFUNCTIONS*



**It is necessary to set up on the monitor, a timer on "injection time" of disinfectant, in order to alarm when a dysfunction occurs and the regulation is overdosing.  
Take in care for all necessary procedures against or after overdosing disinfectant**

## 7. PREVENTIVE MAINTENANCE

### 7.1 Weekly maintenance

A balance or checking of the probe by measuring with a photometer the free chlorine or chlorine dioxide should be performed each week.

Compare the test result with the display on the monitor. If a drift exists, proceed to a new calibration (see previous § 6)

If the drift still exists, proceed to a corrective maintenance of the sensor (see next § 8)

If there is still a defect on the measurement, contact BAMO Mesures SAS for renewing the sensor.

### 7.2 Electrolyte, parts replacement

It is recommended to change the electrolyte each 3 months.

The electrodes, measure and counter electrode should be cleaned each 3 months (see next chapter). It could be done more frequently according to water quality.



## 8. SENSOR CORRECTIVE MAINTENANCE

A cleaning of measuring and counter electrode should be done each 3 months as a minimum. When a preventive maintenance does not result to a correct function and/or when an adjustment of the slope is not satisfactory (unstable reading, low values displayed), proceed to the following maintenance.

*Clogged electrodes*

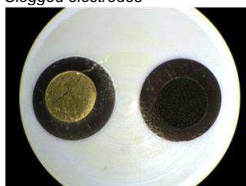

*Dark: counter electrode  
Bright: measuring electrode*

*After Sandpapered*



### **a/ Set down the sensor**

- Disconnect the cable
- Set down the sensor as per § 5.1 reversed operations.

### **b/ Set down the sensor end**

- As per § 4.c and 4.d, reversed operations

### **c/ Electrode cleaning**

- With the special emery paper supplied, clean the bottom of sensor end. Place the emery paper on a flat, horizontal support and rub perpendicularly the sensor end, 2 or 3 times across the abrasive paper.

## **Cleaning when strong deposit occurs**

Lime deposit on electrodes may be removed before the use of abrasive with hydrochloric acid 1% solution during 2 hours. Rinse it with flowing tap water before to use it.

### **To dismantle the sensor for an acid cleaning:**

- Close the water inlet valve
- Disconnect the sensor cable (§ 5.2)
- Set down the sensor as per § 5.1 reversed operations.
- Set down the sensor end as per § 4 reversed operations
- Plunge during 2 hours the sensor end in a 1% HCl solution
- Rinse it with flowing tap water – rinse the lower part of body sensor with tap water
- Dry both parts in a clean place without dust
- Fill in the sensor end with electrolyte as per § 4
- Set up the sensor following steps on § 4 and § 5; proceed to a new calibration as on § 6.

## 9. SENSOR STORAGE



**A sensor AS2 or AS3 not immediately in use should be stored in a fresh, dry place, free from icing. The protection cap must be filled up with tap water.**

When a sensor has been set up once and should be dismantled for more than 1 day, please follow these recommendations:

- Close the water inlet valve
- Disconnect the sensor cable (§ 5.2)
- Set down the sensor as per § 5.1 reversed operations.
- Set down the sensor end as per § 4
- Rinse both parts with flowing tap water
- Dry the both parts in a clean place without dust
- When the system is going to be in use again, clean the electrode as per § 8.
- Set up again the sensor as per § 4 and § 5, proceed then to a calibration § 6.



## 10. OPERATING FEATURES

- The sensor is designed for a vertical mounting, so that the flowing sampled water flush the diaphragm from the bottom.
- Be sure that the pressure is constant. The sensor affords a pressure up to 8 bar (80 m WC). Meanwhile operating, a pressure down will originate some gas bubbles: it does not interfere in the measurement as far as they are not blocked on the diaphragm surface (preventing disinfectant components to enter in the sensor end and causing wrong measurements).
- The sensor may suffer of strong pressure variation, as well as vibrations conducted through the sampled water.
- The ideal flow rate in the cell is 40 L/h; the minimal value is 30 L/h. This flow rate must be stable
- Operating temperature is from 5 to 50°C or 5 to 70 °C acc. to sensor type. The measuring signal is temperature compensated (built in temperature sensor), the output signal then, is free from temperature changes.
- The sensor should be used within the pH range from 5 to 9, and at a constant pH for free chlorine measurement (when pH increases, the measured signal is decreasing).
- The sensor time life is commonly few years and may vary according to water quality. A good care is necessary to clean regularly the electrodes. A factory check up, each year, is recommended
- It is necessary to remove the deposit or pollutants on the electrodes.
- Each sensor is quality control certified. The serial number allows a tracking and is necessary for any complementary information.
- Even in case of maintenance in the main pipe of the plant, the sensor should be kept running with supply from the monitor.
- The sensor must be kept in fluid and electrodes never be dried out.
- The sensor may not work with water without free chlorine more than one day. This causes a bio-film growing on the electrodes and would interfere on measurement quality.
- After any period without disinfectant, addition of disinfectant may be realized (in such a case, use a timer on the regulation until the end of chemical shock operation).
- Before a period of 1 day or more without disinfectant begins, it is convenient to dismount the sensor and store it cleaned and dried.
- For storage, the sensor end and the protection cap must be filled with electrolyte or tap water.
- Existent reagents, oxidants and reducers, as well as corrosion inhibitors, may interfere on the measurement.
- The measuring function is disturbed by surfactants (e.g. tensides).

## 11. ERRORS WHEN OPERATING

According to our knowledge, herein below are typical dysfunctions with possible corrective actions.

DYSFUNCTION	ORIGIN	CORRECTIVE ACTION
<b>Wrong signal value</b>	Polarisation time is too short	Repeat the calibration routine after polarisation (1 hour as a minimum § 6)
	Interference in the signal from the fluid  Short circuit	Look at possible substances interfering. Choose a solution with help of your providers  Find it and correct it. Change the cable if necessary
	Measurement with inappropriate reagent for the photometer or DPD test	Check all and proceed to a new test
	Deposit on the electrodes	Clean the electrodes
	Gas bubbles trapped outside the sensor end	Increase temporarily the flow rate and modify the installation if necessary
	Defective sensor	Change the sensor
	No electrolyte in the sensor end	Fill it with electrolyte
	Chlorine dioxide or free chlorine over ranging	Check all the installation, proceed to necessary modifications and repeat the calibration routine
<b>Unstable output signal</b>	Air bubbles in the electrolyte	Refill the sensor end with electrolyte and check carefully before calibration
	Gas bubbles trapped outside the diaphragm	Increase temporarily the flow rate and modify the installation if necessary
	Sampled water pressure is fluctuating	Check all the installation, proceed to necessary modifications
	Reference electrode is polluted	Send back the sensor to BAMO Mesures SAS for renewing
<b>4-20 mA signal output = 0</b>	Wrong polarity connection	Correct it
	Broken cable	Replace it
	Defective sensor	Send back the sensor to BAMO Mesures SAS for expertise
	Defective monitor	Check the instrument