

IN-LINE TURBIDITY MEASUREMENT SYSTEM TURBICUBE

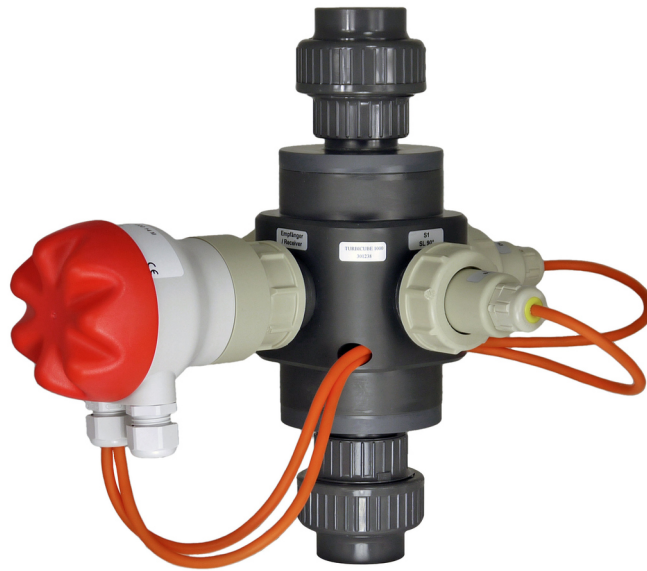

USER MANUAL

BAMO

| | |
|--|--|
| | |
| | |

SAFETY INSTRUCTIONS

- Installation, commissioning and maintenance may only be performed by trained personnel.
- The device may only be connected to a supply power source which complies with the specifications included in the technical data and on the serial plate.
- The device must be disconnected from all sources of power during installation and maintenance work.
- The device may only be operated under the conditions specified in the operating instructions.

DESCRIPTION

TURBICUBE measures the turbidity of the liquid. For this purpose, a combined transmitted light and scattered light measurements are used, in which a transmitter and a receiver face each other and another transmitter is arranged orthogonally (at an angle of 90°). The attenuated and scattered light beams are measured by the evaluation electronics integrated in the connection head and available for further processing. The sensor supplies a 4-20 mA output signal, corresponding to the set range of turbidity.

TURBICUBE 20

5 measuring ranges selectable by DIP switches up to 20 FNU

TURBICUBE 1000

5 measuring ranges selectable by DIP switches up to 1000 FNU

TECHNICAL FEATURES

| | |
|--------------------------------|---|
| Power supply | 24 V DC nominal (10 ... 30 V DC) |
| Connected load auxiliary power | 0.5 ... 1 W |
| Output signal | 4-20 mA |
| Ambient temperature | +5 ... +45 °C |
| Operating temperature | +5 ... +60 °C PVC version +5 ... +80 °C PP version |

Pressure limits: See the diagram

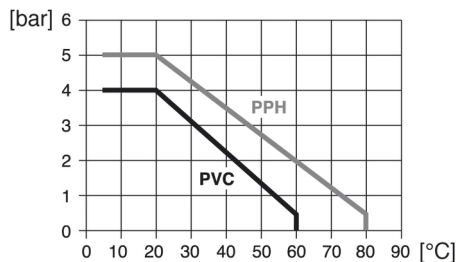

MATERIAL

| | |
|-----------------|--|
| Body | PVC or PP |
| Connection head | PBT glass-fiber reinforced; IP65 according to EN 60529 |
| Seals | EPDM (others on request) |
| Optical windows | Borosilicate glass with CLEANOSIL VMF nanocoating |

TURBIDITY RANGES

| TURBICUBE 20 | | | | | |
|----------------|----------------|-----------------|-----------------|-----------------|------------------|
| DN20...DN100 | 0.01 ... 1 FNU | 0.01 ... 2 FNU | 0.01 ... 5 FNU | 0.01 ... 10 FNU | 0.01 ... 20 FNU |
| TURBICUBE 1000 | | | | | |
| DN20 ... DN65 | 0.1 ... 50 FNU | 0.1 ... 100 FNU | 0.1 ... 200 FNU | 0.1 ... 500 FNU | 100 ... 1000 FAU |
| DN80 ... DN100 | 0.1 ... 50 FNU | 0.1 ... 100 FNU | 0.1 ... 200 FNU | 0.1 ... 300 FNU | 100 ... 1000 FAU |

| | |
|-------------------------------------|--|
| Accuracy | ±5 % of reading, ±1 % F.S. |
| Resolution | 0.001... 0.2 FNU (depending of range) |
| Compensation of Colour/ fouling | Integrated with TURBICUBE 20 up to DN65 |
| Settings | Through DIP switches and potentiometer |
| Signalling | Green LED; Fault: Red LED |
| Process connections: DN 20 to DN100 | PVC unions: for solvent welding PP unions: for fusion welding ISO Flanges ISO 7005 PVC or PP |

CE mark: The device fulfills the legal requirements of applicable EU-guidelines



INSTALLATION

The turbidity measuring system can be installed directly in-line or as a bypass.

Caution

Only for vertical fully loaded pipe, with ascending flow.

Slow down sections: 600 mm before and 400 mm after the device.

It is recommended to provide stop valves before and after the slow-down sections to be able to remove the TURBICUBE for maintenance works.

- The device must be completely filled of liquid during the measurement (possibly, provide for installation in the vertical part of a siphon).
- Air bubbles distort the measurement
- If needed, a throttling may be located after the turbidity system (a throttling before the system distort the measurement)
- Optical windows must be clean regularly, according to the application.

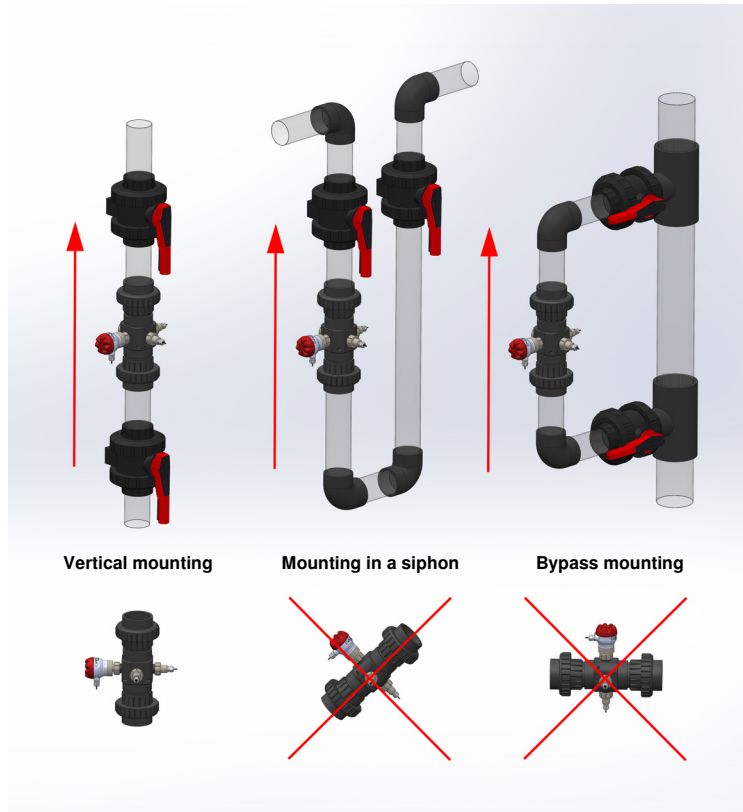

FASTENING

There are 4x M6 blind threaded holes on the TURBICUBE body which can be used for additional support on a bracket. The PVC wall fastening is available as an option; Consider the following diagram:

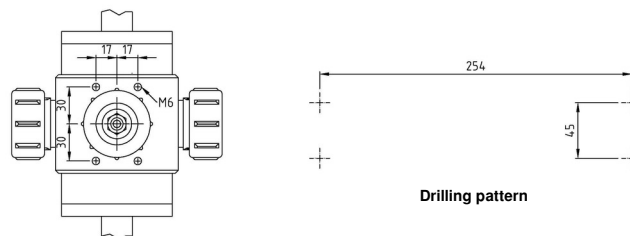

BAMO



TURBICUBE 20 SETTINGS

The sensor set consists of one receiver module and two emitter modules.
 The measuring ranges are set via the DIP switches inside the receiver module.
 The sensor set provides a 4-20 mA output signal, corresponding to the set range, according to the following diagram:

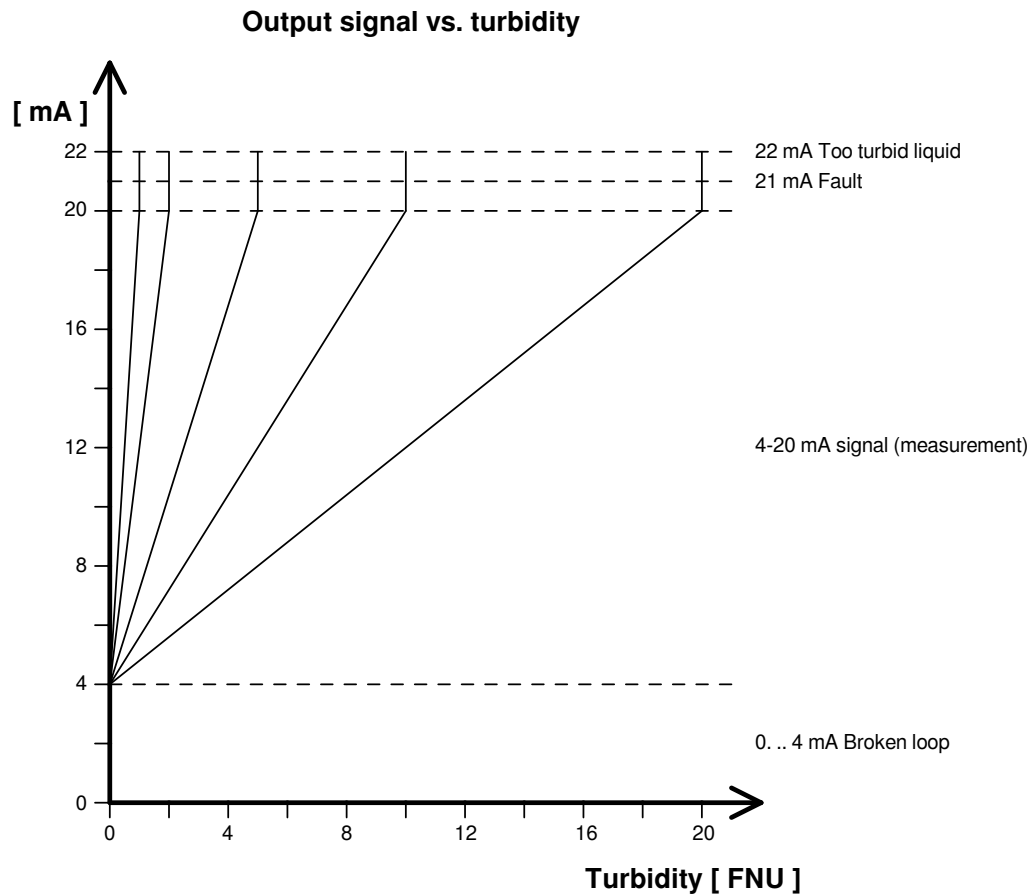

DIP switches setting

| Range [FNU] | DIP1 | DIP2 | DIP3 | DIP4 | DIP5 | DIP6*) |
|----------------|------|------|------|------|------|--------|
| 1= 0.01 ... 1 | ON | ON | OFF | OFF | OFF | OFF |
| 2= 0.01 ... 2 | OFF | OFF | ON | OFF | OFF | OFF |
| 3= 0.01 ... 5 | ON | OFF | ON | OFF | OFF | OFF |
| 4= 0.01 ... 10 | OFF | ON | ON | OFF | OFF | OFF |
| 5= 0.01 ... 20 | ON | ON | ON | OFF | OFF | OFF |

*) with DIP 6 = ON --> Compensation of colour/ fouling is switched on.
 Note: This function is only available for fittings up to DN65



TURBICUBE 1000 SETTINGS

The sensor set consists of one receiver module and two emitter modules.
 The measuring ranges are set via the DIP switches inside the receiver module.
 The sensor set provides a 4-20 mA output signal, corresponding to the set range, according to the following diagram:

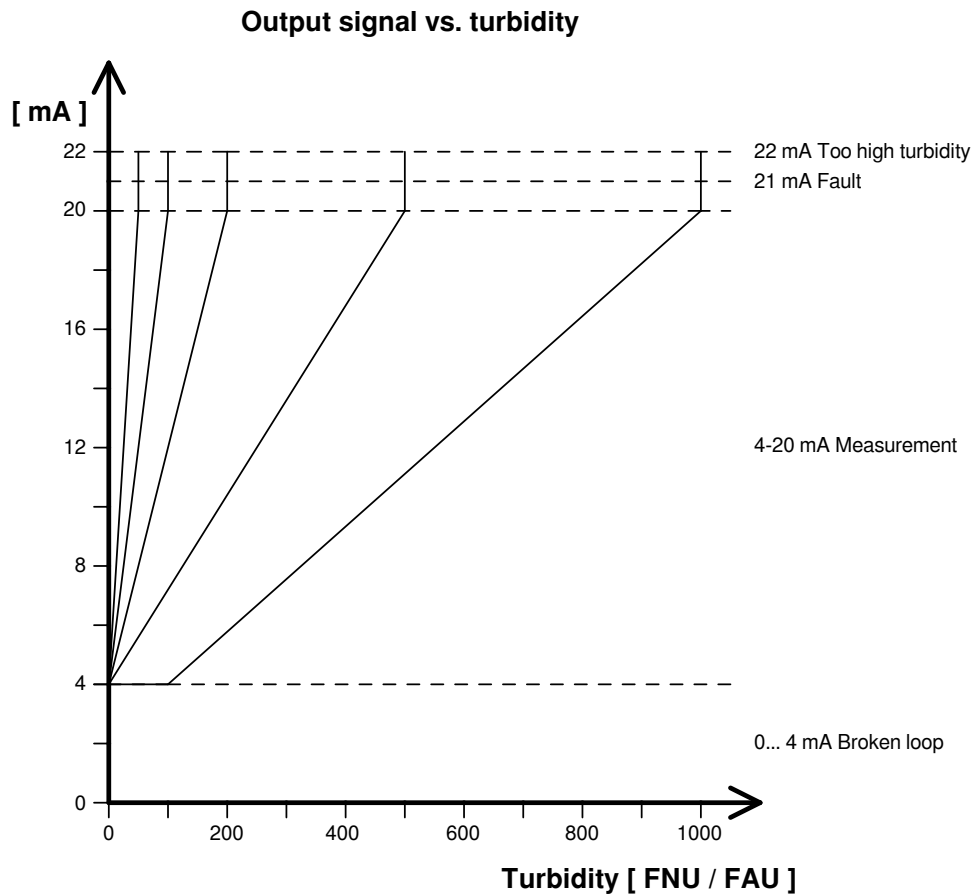

DIP switches setting

| Range [FTU] | DIP1 | DIP2 | DIP3 | DIP4 | DIP5*) | DIP6*) |
|-------------------------|------|------|------|------|--------|--------|
| 1 = 0.1 ... 50 | OFF | OFF | OFF | ON | OFF | OFF |
| 2 = 0.1 ... 100 | ON | OFF | OFF | ON | OFF | OFF |
| 3 = 0.1 ... 200 | OFF | ON | OFF | ON | OFF | OFF |
| 4 = 0.1 ... 500 (**300) | ON | ON | OFF | ON | OFF | OFF |
| 5 = 100 ... 1000 | OFF | OFF | OFF | OFF | OFF | OFF |

*) Do not switch DIP 5 and 6: Always position = OFF

**) for DN80 and DN100

BAMO



OPERATING DISPLAY / FAULT MESSAGES

Green LED flashes approx. each second, signal is within 4 ... 20 mA
 Green LED flashes, signal is 22mA

Red LED lights up, signal is 0 mA
 Green LED steady light, signal is 21mA

Red LED flashes, signal is within 4 ... 20 mA : only for on TURBICUBE 20

Green LED off

Unit ready for operation
 Turbidity is overrange (> 5 %)
 - Light beam reaches the receiver, but the turbidity is too high for the set range.
 - Or, DL and SL transmitters were inverted during reassembly after maintenance works.
 Fault in the measuring loop (broken loop / short circuit)
 Other faults
 - Turbidity is so high that no more light can reach the receiver
 - Transmitter is not connected or not correctly
 Colour/ fouling compensation not possible
 - Optical windows too dirty or too much liquid discoloration = attenuation > 20 dB
 Supply voltage is missing, or, the unit is defective

SETTING

Note:

The turbidity-meters are calibrated with the international standards of formazin dilutions.
 Measured values from other turbidity-meters using other calibration suspensions, measuring angles and light source, cannot be directly compared with those of meters calibrated according the directive ISO 7027.

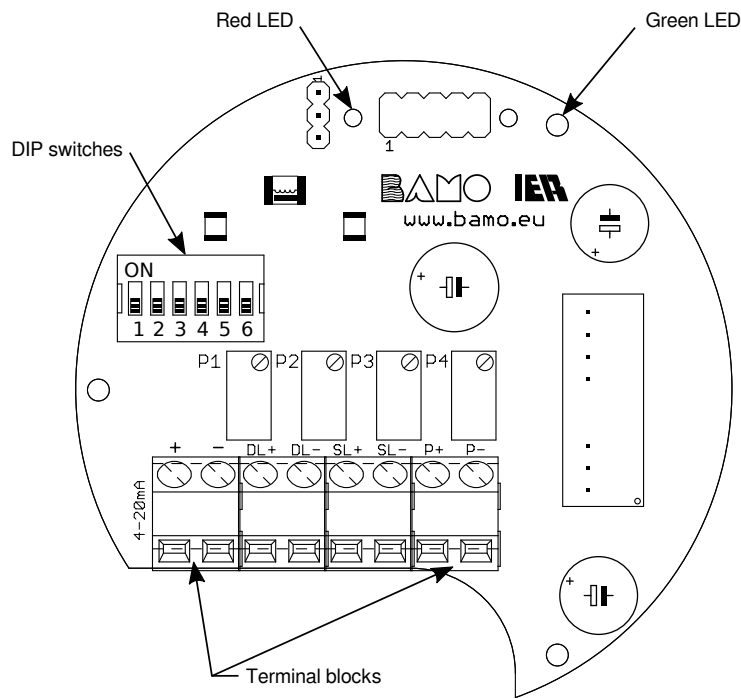

ELECTRICAL CONNECTION

TURBICUBE 3-wire connection

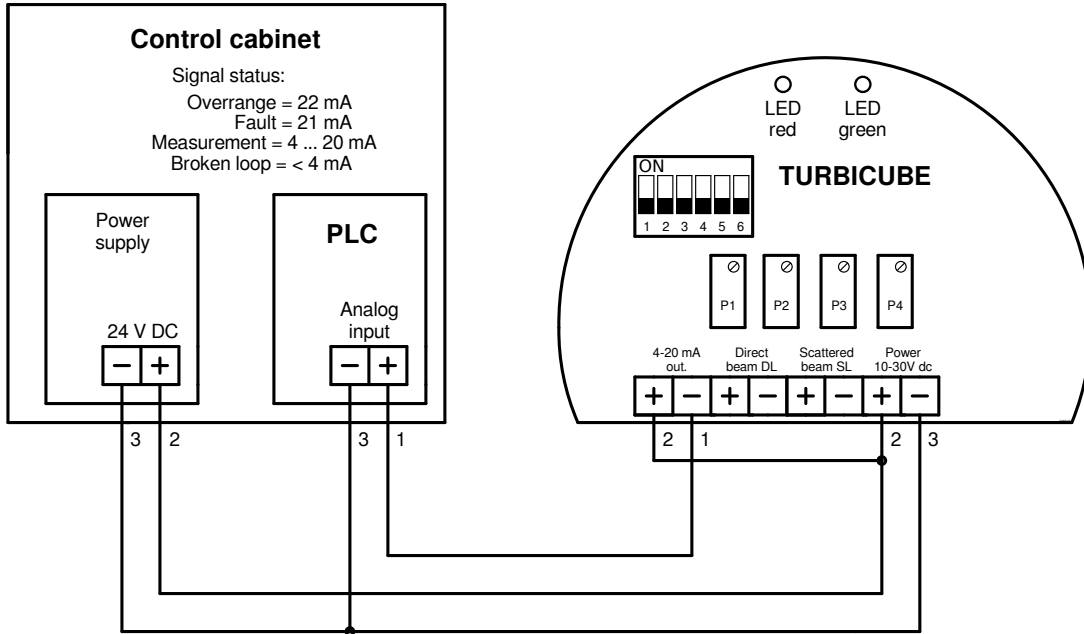

TURBICUBE 4-wire connection

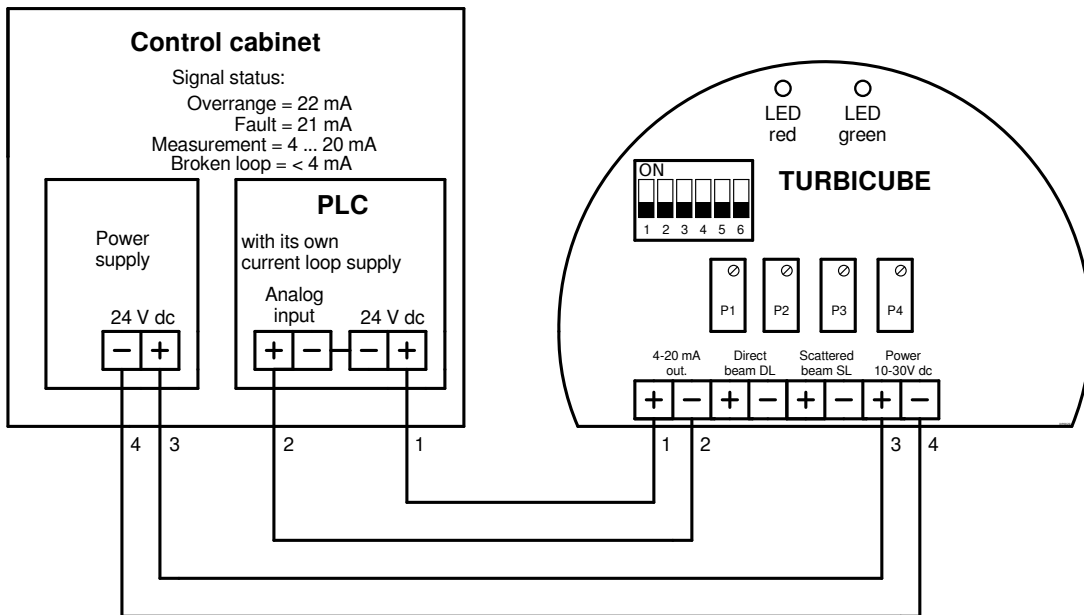

TURBICUBE with a BAMOPHAR TUR 230 V ac model

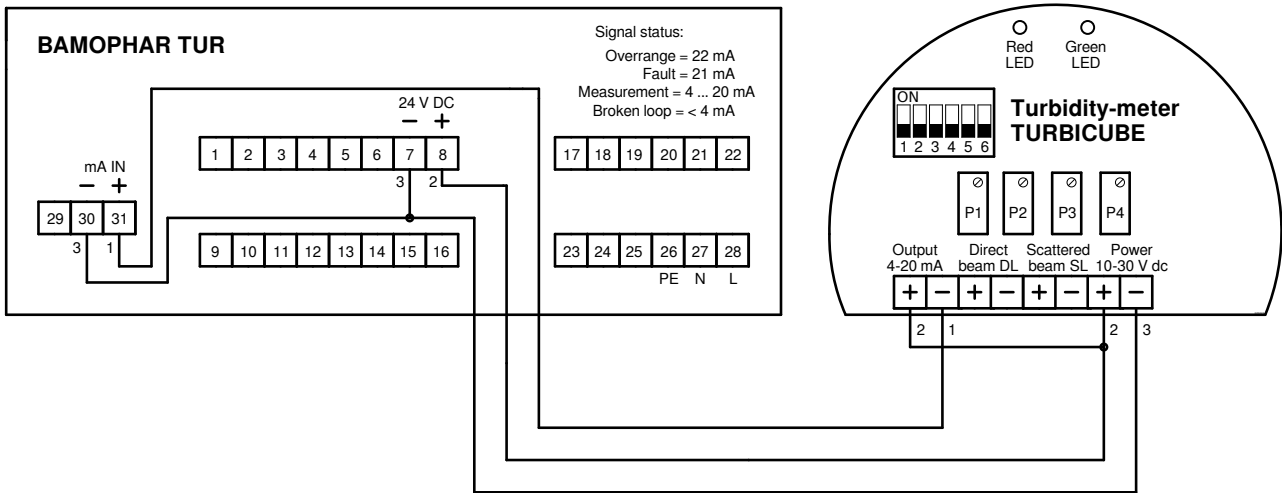

TURBICUBE with a BAMOWIZ 213

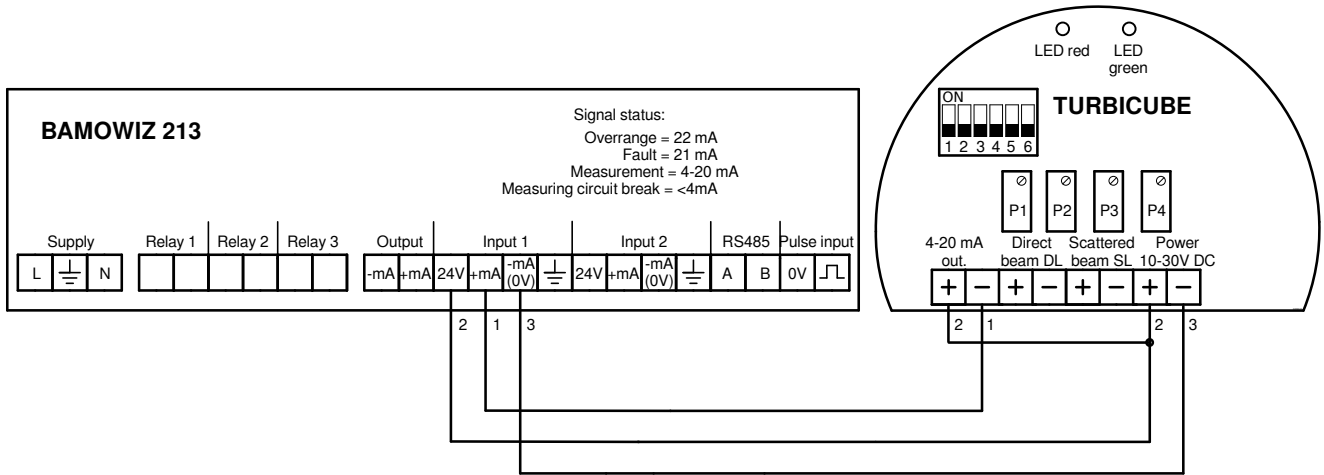

MAINTENANCE

Frequency of cleaning tasks depends on the liquid and must be determined by the end-user.

For cleaning: It is recommended to completely remove the device from the piping; For this purpose, shut-off valves should be installed upstream and downstream of the device (Slow down sections to be respected).

Cleaning the optical windows:

- Disconnect the TURBICUBE from power and/ or PLC
- Depressurize the pipe and drain it
- Remove the transmitters and receiver by unscrewing the union nuts.
 - Unscrew the ETR washers with the supplied tool and open-end wrench (SW17) or a rod (screwdriver) inserted into the tool bore
- Then clean the windows; Do not use any scratching cleaning agents!

ASSEMBLY

Caution: Before reassembling, be sure that all parts are dry and free from contamination.

Note: If necessary, replace the seal ring before reassembly.

Only use original BAMO IER sealing rings.

- Tighten ETR washers with a torque wrench (5 ... 6 Nm)

Torque wrench
TURBICLICK 5.7 code
Nr 444910 (option)

- Perfectly dry all parts before final assembly.
Reinstall the TURBICUBE in piping only with all optical windows well tightly screwed on TURBICUBE.
- Refill the piping and check for leaks before remounting the receiver and emitters.

Note the pin (take care of the hole-key corresponding to the pin).

Take care of the hole-key during reassembly (note the corresponding pin).

The logo for BAMO, featuring the letters 'BAMO' in a stylized, red-outlined font. The 'B' has a wavy pattern on its left side.