

BAMOMATIC

Electromagnetic flowmeter



INSTRUCTION MANUAL

BAMO MESURES

22, Rue de la Voie des Bans - Z.I. de la Gare - 95100 ARGENTEUIL
Tél : (+33) 01 30 25 83 20 - Web : www.bamo.fr
Fax : (+33) 01 34 10 16 05 - E-mail : info@bamo.fr

Electromagnetic flowmeter
BAMOMATIC

22-05-2012

775 M1 01 D

MES

775-01/1

1. CAUTION

The mounting on site of a BAMOMATIC should strictly follow these recommendations.

The 2 flow meter electrodes have to be imperatively in a permanent contact with the fluid. According to pic. 1, the upward and downward lengths of the pipe (respectively upstream and downstream) should be as long as possible; the pipe diameter should correspond to the connection diameter. Avoid elbows, valves and obstruction close to the flow meter. Non respect of those conditions may originate lowest performance. It is not convenient to install a BAMOMATIC close to a heating device and/or a powerful magnetic field.

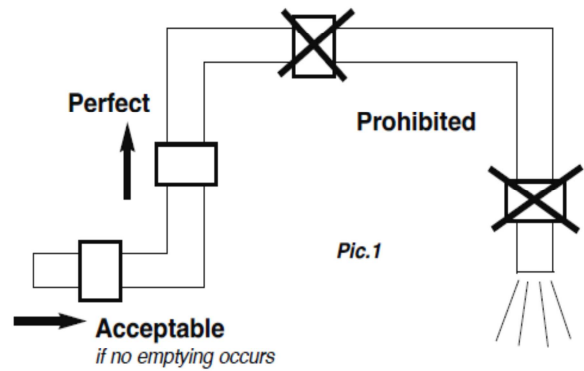

2. WIRING WITH ELECTRONIC DEVICES FROM BAMO

Wiring to BCP 48 device

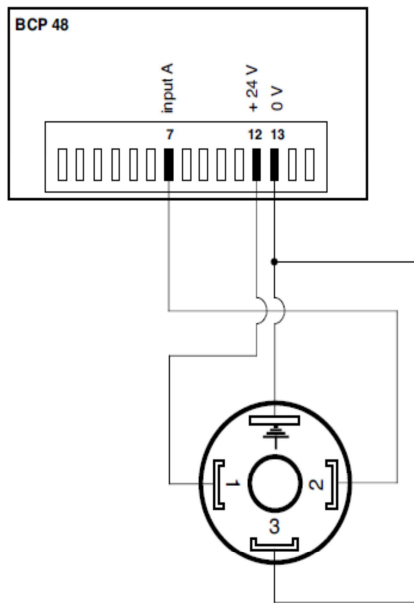

Wiring to BIF 6040 device

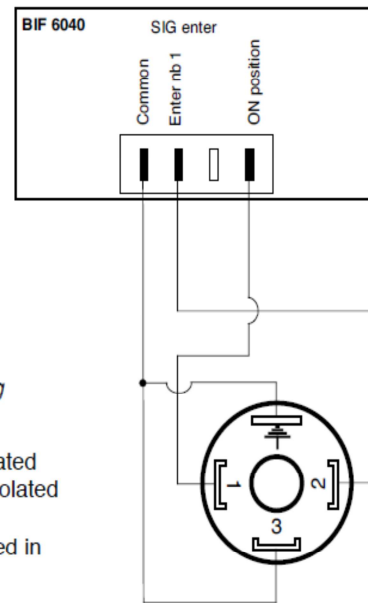

BAMOMATIC

Wiring DIN 43650 plug

Pin 1: Power supply +24 V dc
 Pin 2: Output collector opto-isolated
 Pin 3: Output transmitter opto-isolated
 Pin Earth: 0 V dc
 Correct load resistance integrated in the electronic device

3. WIRING TO PLC OR SPECIFIC DEVICES

Caution: Never use the instrument without a load resistance.
 Check the load resistance "R" before connecting the power.

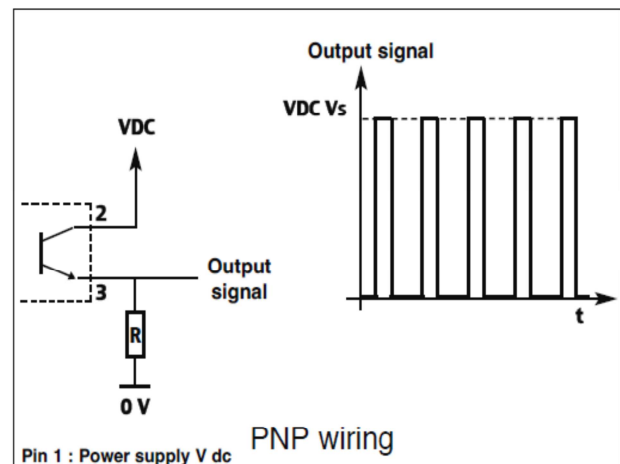
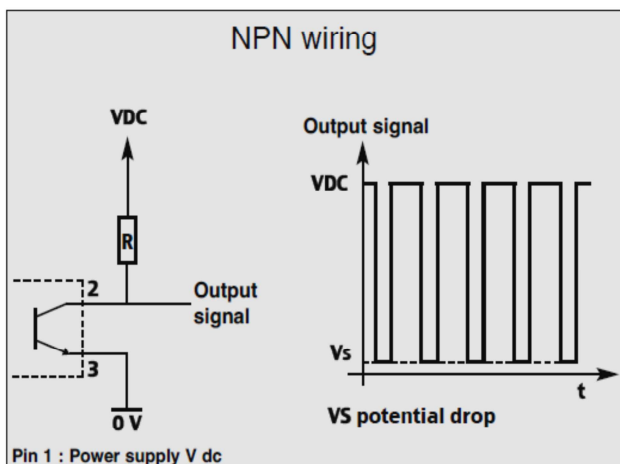

With the option 12 V DC power supply: Resistance value R for VDC = 12 V **R = 1000 Ω**
 Standard model 24 V DC power supply: Resistance value R for V dc = 24 V **R = 2000 Ω**

Transistor features: Type NPN – V DC max. = 28 V – I max. = 50 mA
 Diode and poly-switch protected

4. PROCESS CONNECTIONS

A water tightness connection may be realized with the 3 components A, B and C.
(These components are not delivered with the BAMOMATIC)

The material of the seal "A" may be chemically compatible with the fluid! .

Never tight any connection on the BAMOMATIC housing

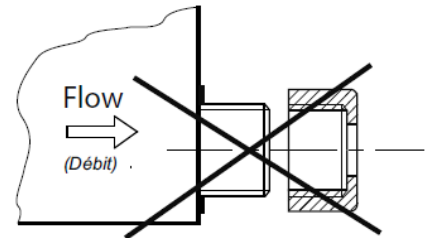
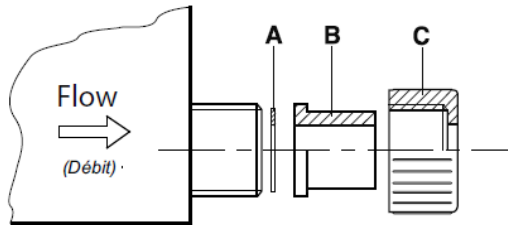

5. TECHNICAL FEATURES

Power supply:	24 V DC / ± 3 V DC
Consumption:	20 mA / 0.65 W
Protection:	Against polarity inversion
Output signal:	NPN Type
Status indicators:	Red LED = powered Green LED = output (pulses)
Wiring:	DIN 43650-A Plug
Process connection:	½", ¾", 1" or 1 ¼" (vs. model)
Nominal diameter:	8 mm, 14 mm, 18 mm, 25 mm (vs. model)
Pipe material:	PVDF, red color excepted 1 ¼" model, POM (Delrin) blue color
Tube and electrodes:	Stainless steel 316 L
Mass:	250...690 g
Minimal conductivity:	20 µS
Maximal pressure:	10 bar /20°C – 8 bar /40°C – 6 bar /60°C
Operating temperature:	-10°C to +60°C

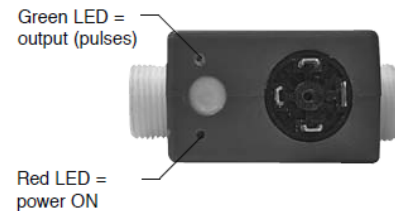

Model	A	B	Ø C	D	E	F	G	ND
½"	84,5	18,5	½" MG	80	36	88	100	8
¾"	90	20	¾" MG	80	36	88	100	14
1"	90	22	1" MG	80	36	88	100	18
1 ¼"	115	36,5	1 ¼" MG	64	60	130	155	25

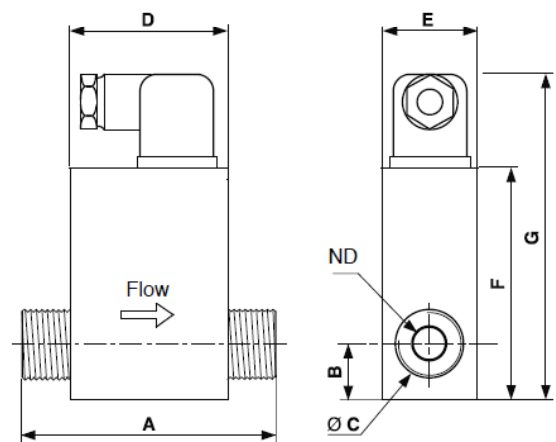

6. CODE NUMBERS AND REFERENCES

Power supply 24 V DC			Pulse output			
POM pipe	PVDF pipe	Range L/min	Ø	Hz / L/min	Range Hz	Pulse / L
–	775 301	0.25 to 5	½"	16,6667	1,6 à 83	1000
–	775 302	1 to 20	½"	13,3333	13 à 267	800
–	775 303	2.5 to 50	¾"	2,6666	5 à 134	160
–	775 304	5 to 100	1"	2,6666	13 à 267	160
–	775 305	10 to 150	1"	1,3333	13 à 200	80
775 006	–	12.5 to 250	1 ¼"	1,6666	19 à 383	100